



Version: 29.04.2019

Imagery may include optional equipment

Changes reserved

20.07.06.0005



Cosber - Brake Tester for Truck

C-BTT 5x/6x/7x/8x Series

Cosber GmbH
Bretonischer Ring 12
85630 Munich-Grasbrunn
Germany

Office: +49 (0) 89 262 07 66-00
Fax: +49 (0) 89 262 07 66-60
Email: info@cosber.de
www.cosber.de

Cosber - Brake Tester Truck



C-BTT series for 13t and 18t axle load:

- ▶ Hydraulic load simulation
- ▶ Four wheel drive (4x4)
- ▶ With automatic gear motor lock function to facilitate the driving in and out of vehicles
- ▶ Two-speed operation mode with lifting load, adapt to different types of vehicle
- ▶ Mechanical components with hot-dip galvanization for protection against corrosion.

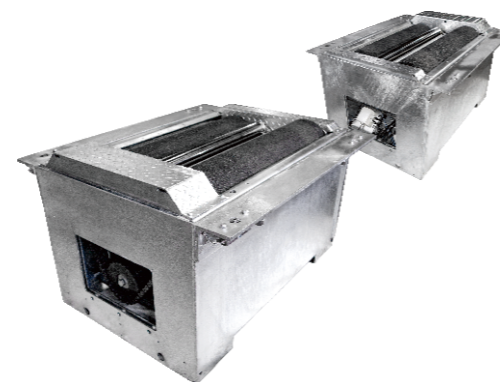

C-BTT 5x/6x/7x/8x

Hydraulic load simulation

- ▶ Hydraulic lifting function with lifting height of 200mm and improved testing of multi-axis vehicle
- ▶ Controlled by radio remote control
- ▶ Suitable for almost all trucks and trailers



Technical parameters

| Equipment model | C-BTT 5x/6x | C-BTT 7x/8x |
|-------------------------------------|--------------------------------------|--------------------------------------|
| Maximum drive over load | 13000 kg | 18000 kg |
| Measurement range | 0 ~ 40000 N | 0 ~ 40000 N |
| Wheel track width | 1000~3000 / 1100~3100 / 1200~3200 mm | 1000~3000 / 1100~3100 / 1200~3200 mm |
| Roller diameter | Ø 208 mm | Ø 248 mm |
| Roller length | 1000 mm | 1000 mm |
| Coefficient of friction (dry / wet) | > 0.7 / 0.6 | > 0.7 / 0.6 |
| Roller test speed | 2.5 ~ 5 km/h | 2.5 ~ 5 km/h |
| Roller height difference | 30 mm | 50 mm |
| Motor power | 9 kW 11 kW | 15 kW 13~17 kW |
| Dimensions (L x W x H) | 3220 x 1040 x 686 mm | 3490 x 1240 x 806 mm |
| Equipment weight (ca.) | > 1500 kg | > 1700 kg |

Lifting Device (Control Box)

- ▶ Remote control for hydraulic load simulation
- ▶ Control box for hydraulic load simulation

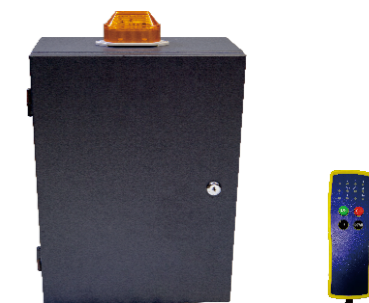

Analog – Display



Swivel arm and column mounting

Indicator

- ▶ Brake force
- ▶ Operating mode: Manual, Automatic, 4 x 4
- ▶ User guidance
- ▶ Weight in kg (if weight sensors included)
- ▶ Digital difference displayed in % at LED-display
- ▶ Road adhesion in % for suspension tester
- ▶ Difference for side slip tester in m/km
- ▶ Status lights for different operating modes

| Technical parameters | |
|--------------------------------|-----------------------|
| Dimensions (L x W x H) | 830 x 200 x 610 mm |
| Equipment weight | 25 kg |
| Protection class | IP54 |
| Braking force range | 0 ~ 40000 N |
| Minimum braking force | 100N |
| Side-slip displacement range | -20 mm ~ 20 mm |
| Minimum side-slip displacement | 4 mm |
| Screen display range | 16 characters, 1 line |
| Braking force display accuracy | 1 N |

Control Box



Remote Control



Air pressure sensors



Pedal force sensor

Technical parameters

| | |
|---|--|
| Dimensions (L x W x H) | 1050 x 600 x 360 mm |
| Equipment weight | 60 kg |
| Power supply | AC 3-phase x 400V + PE /50Hz AC 3-phase x 230V + PE/60Hz (optional) |
| Rated current | 400V - 12A 230V - 20A (optional) |
| Power cable requirements (provided by customer) | 5 x 2.5 mm (3P + N + PE) |

Calibration Tool

- ▶ Easy to operate
- ▶ High-precision calibration
- ▶ Fast measurement
- ▶ Calibration case (optional)



Software

The screenshot shows the 'Brake slowly' interface with two large circular gauges for left and right brake force. The left gauge shows 6,03 kN and the right gauge shows 24,63 kN. A 'Loosen' button is visible between the gauges. On the right side, there is a vertical list of data: Difference (%) 2, Efficiency (%) 60, Axle Weight (kg) 955, Pedal force (N) 74, PX NO. 1, PX [bar] 0.0, and PM [bar] 0.0. A 'Back' button is at the bottom right.

Labels pointing to the interface include:

- Info text message
- Left real-time brake force clock
- Action info symbol
- Testing mode
- Currently tested axle
- Right real-time brake force clock
- Difference between left and right brake force in percent
- Motor start
- Wheel Lock warning
- Test check list information
- Pressure applied in the brake system
- Value of pressure sensor
- Number of pressure sensor
- Measured actuation pressure
- Axle load
- Efficiency value calculated from axle brake force and axle weight in percent

Cosber brake tester software test screen

The screenshot shows the 'Ovality measurement' interface with two gauges for left and right brake force. The left gauge shows 6,03 kN and the right gauge shows 24,63 kN. A 'Loosen' button is visible between the gauges. On the right side, there is a vertical list of data: Difference (%) 2, Efficiency (%) 60, Axle Weight (kg) 955, Pedal force (N) 74, PX NO. 1, PX [bar] 0.0, and PM [bar] 0.0. A 'Back' button is at the bottom right.

Ovality measurement

The screenshot shows the 'Guided test procedure' interface with a central graphic of a truck chassis and a 'Park' button on the left. A 'Back' button is at the bottom right.

Guided test procedure

The screenshot shows the 'Vehicle information' interface with a form for 'Vehicle definition' and a table for 'Inspection Options'.

| Axle count | Service brake | Parking brake | Sensor PX NO | Pressure [bar] |
|------------|--------------------------|--------------------------|--------------|----------------|
| 1 | <input type="checkbox"/> | <input type="checkbox"/> | 1 | 0.5 |
| 2 | <input type="checkbox"/> | <input type="checkbox"/> | 2 | 0.5 |
| 3 | <input type="checkbox"/> | <input type="checkbox"/> | 3 | 0.5 |
| 4 | <input type="checkbox"/> | <input type="checkbox"/> | 4 | 0.5 |
| 5 | <input type="checkbox"/> | <input type="checkbox"/> | 5 | 0.5 |
| 6 | <input type="checkbox"/> | <input type="checkbox"/> | 6 | 0.5 |

Configuration of axles and air-pressure sensor

The screenshot shows the 'Self-Check' interface with sections for 'Digital Input', 'Analog Input', and 'Speedo Input'. It includes buttons for 'Run', 'Stop', and 'End'.

Self-check analog, digital, speedo, weight signal

Features

- ▶ Improved user interface
- ▶ Intuitive use
- ▶ Database functions
- ▶ Print and digital test results



C-BTT foundation

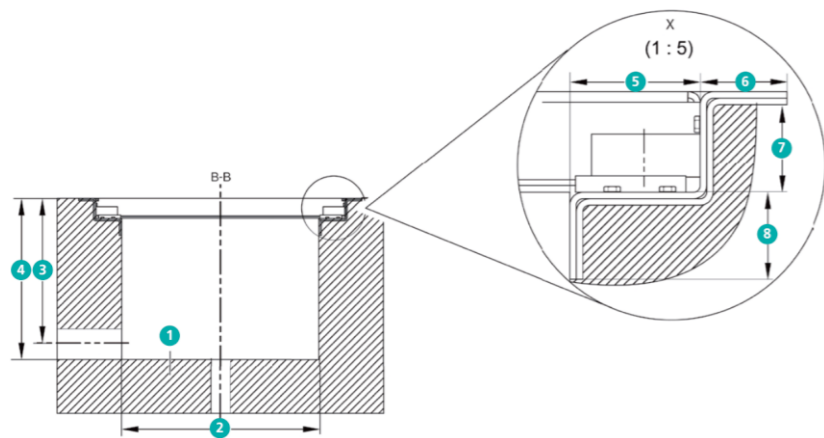

- ▶ Easy to install as the hydraulics of the load simulation are already integrated into the case of the roller set.
- ▶ Easy to fit into common foundations.
- ▶ Simply remove the old tester and install the new one.

Prerequisite to the foundation

| Pos. | BTT 5x/6x | BTT 7x/8x |
|------|---------------------------|---------------------------|
| 1 | C20/25 (DIN EN 19992-1-1) | C20/25 (DIN EN 19992-1-1) |
| 2 | 820 mm | 920 mm |
| 3 | 575 mm | 675 mm |
| 4 | 650 mm | 750 mm |
| 5 | 120 mm | 120 mm |
| 6 | 80 mm | 80 mm |
| 7 | 93 mm | 93 mm |
| 8 | 80 mm | 80 mm |

Variants for installation with or without pit

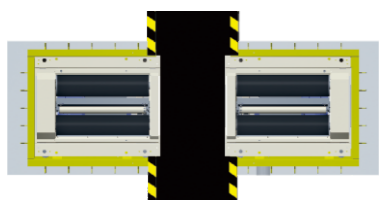

With pit: two separate foundation frames as edge protectors



Without pit: one foundation frame

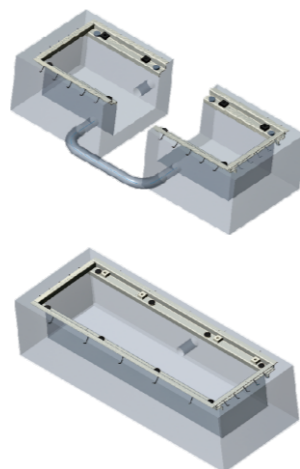

Installation accessories

| BTT 5x/6x | BTT 7x/8x |
|---|---|
| separated pit-frame with 1000mm rollers | separated pit-frame with 1000mm rollers |
| non-separated (w/o pit) frame, track width 2700mm | non-separated (w/o pit) frame, track width 3000mm |
| non-separated (w/o pit) frame, track width 2800mm | non-separated (w/o pit) frame, track width 3100mm |
| non-separated (w/o pit) frame, track width 2900mm | non-separated (w/o pit) frame, track width 3200mm |

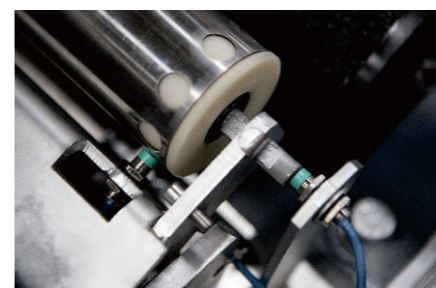

Proximity switch

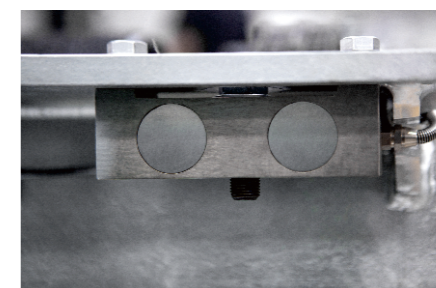

Weight sensor



Roller chain

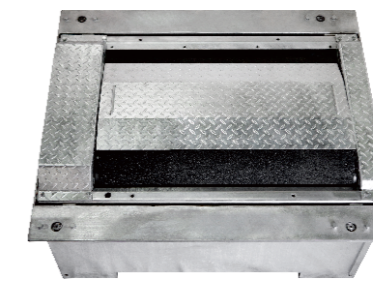



Roller cover plate

Configuration

| Equipment | Type | Standard | | Option | |
|-----------------|-------------------|--------------------------|--------------|-------------------------|--------------|
| | | BTT 5x/6x | BTT 7x/8x | BTT 5x/6x | BTT 7x/8x |
| Brake Tester | Roller type | Corundum | | Spike | |
| | Roller length | 1000 mm | | 1000 mm | |
| | Weight system | - | | 8 Weight sensors | |
| | Motor power | 2 x 9/9 kW | 2 x 13/17 kW | 2 x 11/11 kW | 2 x 15/15 kW |
| | Frame surface | Hot-dip galvanized | | Spray painted (Green) | |
| | Speed sensor | Yes | | - | |
| | Lifting function | - | | Yes | |
| | Lifting height | 200 mm | | 200 mm | |
| | Lifting load | 4000 kg | | 4000 kg | |
| Control Cabinet | Drive type | Two-wheel drive mode | | Four-wheel drive mode | |
| | Drive out support | Electroautomatic | | Electro-magnetic Brake | |
| | Asa communication | Yes | | - | |
| | Supply voltage | Three-phase AC 400V/50Hz | | Three-phase AC230V/60Hz | |
| | Remote control | - | | Yes | |

Accessories

| Item number | Name | Picture |
|---------------|-------------------------------|---|
| 20.02.15.2001 | Analog Display 0 - 40 kN |  |
| 20.02.15.2003 | Swivel arm for Analog Display |  |
| 20.02.15.2002 | Column |  |
| 20.07.00.1020 | Lifting device |  |
| 20.02.01.9921 | Remote control |  |
| 20.05.00.2021 | Weight sensor set |  |

| Item number | Name | Picture |
|---------------|---|---|
| 20.05.00.1021 | Air pressure sensor set |  |
| 20.05.03.1025 | Pedal force meter |  |
| 20.99.03.1005 | Calibration device |  |
| 20.02.01.9920 | PC cabinet |  |
| 20.05.15.3001 | Roller cover plate 13t (C-BTT 5x/6x) |  |
| 20.07.01.0048 | Roller cover plate 18t (C-BTT 7x/8x) |  |
| 20.05.00.1002 | Pit safety KIT 1 (2,5 m) |  |
| 20.05.00.1003 | Pit safety KIT 2 (1,5 m x 2,5 m) |  |
| 20.05.00.1004 | Pit safety KIT 3 (2,5 m x 2,5 m) |  |
| 20.06.00.1000 | Pit safety swivel arm lengthwise (25 m) |  |
| 20.07.04.0701 | PC-Connection and PC-Visualization Truck Software (without car) |  |
| 20.07.04.0702 | PC-Connection and PC-Visualization Truck Software (with car) |  |